



Model 907/908

Measurement System

Features

- Menu Driven
- Measurement Functions
DC/AC/PEAK/MAX HOLD/STORE
- Measurement Units
Gauss, Oersteds, Tesla or Amps/Meter
- Operating Functions and Units Displayed
- RS232 Interface (908)
- Battery Operated
- External Power Supply Connection (908)
- Multilingual
- Thin Semi-Flexible Probe
- Visible Measurement Point
- Probe Polarity Indication
- Two Line, Sixteen Character, Dot Matrix, Liquid Crystal Display
- Single Button Range Changing
- Adjustable Auto Power Down Feature
Extends Battery Life
- Hall Element Calibration Data Stored and
Used For Auto Correction of Readings
- Data Capture Button

Description

The Model 907 and Model 908 microprocessor controlled Gaussmeters offer sophisticated measuring functions with selectable units in a simple to use, menu driven, hand-held package.

The 907 & 908 are designed for factory floor, incoming inspection/quality assurance and laboratory measurement of Magnetic Flux Density and Magnetic Field Strength in SI or CGS units. The polarity, measurement value, measurement units, and measurement functions are displayed on a two line, sixteen character, dot matrix, liquid crystal display.

Introduction

The Model 907 and Model 908 Gaussmeters have been designed and manufactured with more than 30 years experience in magnetic measurement. This experience and our extensive knowledge of the magnetics market has enabled us to offer an instrument incorporating all of the measurement functions a user is ever likely to need. The Model 907 & 908 are controlled by a simple menu and supplied with a thin, semi-flexible Transverse Hall Probe suitable for all but the very smallest of applications.

The Model 907 & 908 incorporate an Analog Peak Detector for the DC and AC peak functions. This, coupled with the microprocessor operation of the Model 907 & 908, means that fast response is possible with digital stability (fast pulses/no droop in readings).

Applications

The 907 is ideal for inspection and measurement of magnetic flux density of magnets and magnet assemblies in both incoming inspection and Quality Assurance environments. Where individual measurements need to be recorded the Model 908 will store and upload not only the measured values, polarity, measurement units and measurement function, but also the time at which the measurement was taken.

Other menu options

- A "Units" selection to change between Tesla, Amps/m, Gauss and Oersted.
- A "Capture" option. This enables you to choose between storing, recalling and holding readings in memory.
- The "Utilities" option enables you to choose between a number of lesser used functions such as Null (Zeroing), self calibration process, control of automatic power down timing and even a language option including English, French, German, Italian, Spanish and Portuguese.

Features Available Only With The Model 908

The Model 908 includes all of the functions of the Model 907 plus:

- An RS232 interface including an adapter to provide RS232 communication for uploading measurement data to a host computer. The Model 908 can also be remotely controllable via this link. Software supplied for IBM PC.

The Model 908 incorporates a non-volatile memory to enable the retention of stored values even when switched off.

- The Model 908 incorporates a time keeping device so that the time when data has been stored can also be recorded. Also an external PSU for bench top applications.

The Hall Probe

Both the Model 907K (Kit) and the Model 908K (Kit) are supplied with a transverse Hall probe as standard. The design of the Hall probe is critical to the satisfactory operation of any Gaussmeter. For the Model 907 and Model 908 we have used our extensive industrial experience to produce a transverse Hall probe which is semi-flexible and only 1 mm thick by 4 mm wide. This enables operators to take measurements in tight spaces and narrow air gaps. In addition the sensitive Hall element is clearly visible so that the user knows exactly where the measurement is being made. The probe is fitted with a push button enabling the operator to HOLD and STORE measurements and to orient the probe for polarity readings. An axial probe is also available as an optional extra. This is only 5 mm in diameter and also incorporates a push button for HOLD and STORE functions. All transverse and axial probes are fully interchangeable on both the Model 907 and Model 908 without the need for re-calibration.

Model 907 & 908 Probes

Transverse Hall Probe - 230 mm

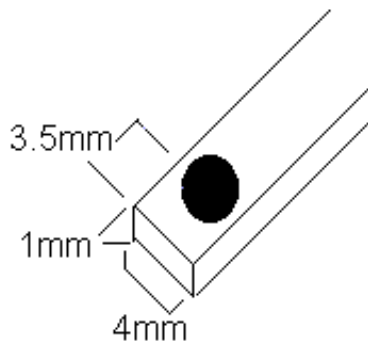
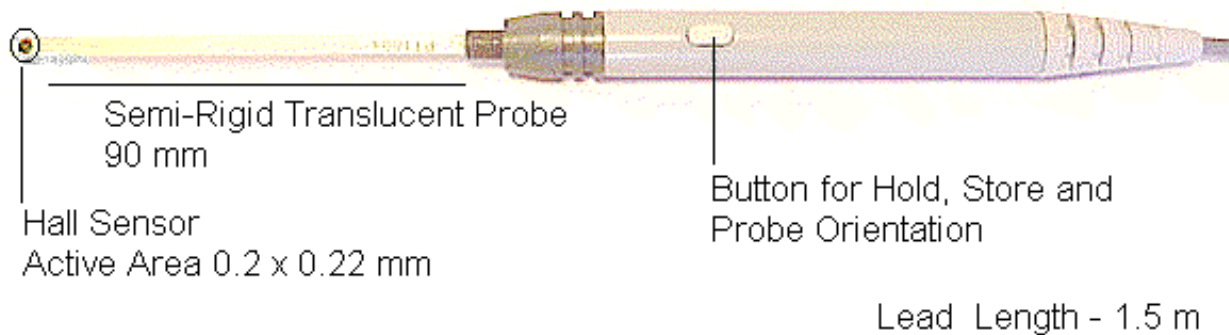

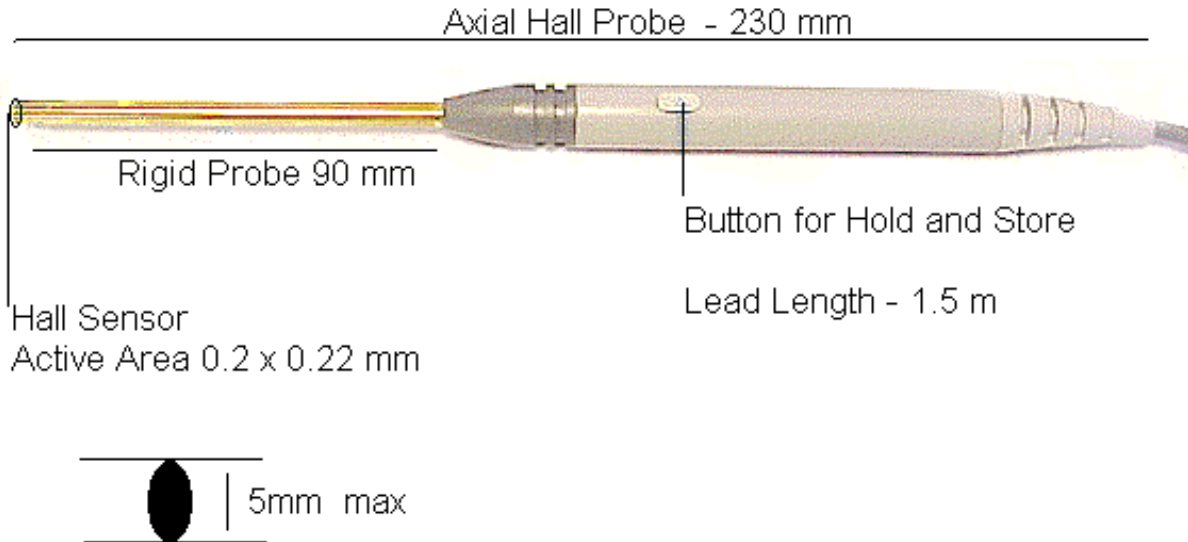

Specifications

AUTO AND MANUAL RANGING

Range 1

0 - to more than 30,000 Gauss — Resolution 10 Gauss
 0 - to more than 3 Tesla — Resolution 1 milli Tesla.

Range 2

0 - 30 Gauss — Resolution 1 Gauss
 0 - 299.9 milli Tesla — Resolution 100 micro Tesla.

Range 3

0 - 3 Gauss — Resolution .1 Gauss
 0 - 29.99 milli Tesla — Resolution 10 micro Tesla.

Range 4

0 - .300 Gauss — Resolution .02 Gauss
 0 - 2.999 milli Tesla — Resolution 2 micro Tesla.

Measurements can be made in Tesla, Gauss, Amps/m or Oersted.

(1mT = 10 Gauss = 0.796 kA/m)

Accuracy (at 20° C): ± 1% Reproducibility ± 0.5%

Temperature Coefficient: Better than ± 0.1% of reading / °C including probe.

Frequency Range: DC and 15Hz to 10 kHz.

Averaging Time Constant: 100 milliseconds.

Functions: DC, DC Peak, AC RMS, AC RMS MAX, AC PEAK

Display: 2 line, 16 character dot matrix LCD

Display Sampling Rate: 3/sec (approx.)

Operating Temp. Range: 0°C to +50°C

Storage Temp. Range: -20°C to +70°C

Battery Type and Life: 9V Long life Alkaline (Duracell MN1604) or similar (not supplied). Battery Life Approximately 15 Hours continuous operation. Auto Power-down after 1, 4 or 10 minutes or can be disabled, all under menu control.

Facilities: Store and Recall on 0 - 99 samples. Hold facility. Analog Peak with digital storage. Auto and manual ranges. Automatic reading conversion between different units. Operating set up at time of power-down is stored and recalled automatically at power-on. Utilities etc. Functions are selected with an easy to use menu.

Dimensions

Length 7.72 in (196 mm)
 Width 3.94 in (100 mm)
 Height 1.57 in (40 mm)

Weight (inc. battery): 14 Ounces (400g not including probe)

Standard Accessories

Transverse Hall Probe, Zero Flux Chamber and Carrying Case

Optional Accessories:

Axial Probe Ref AP002. Replacement Transverse Probe Ref TP002. Reference Magnets Axial and Transverse - contact factory for details.

MODEL 908 ADDITIONAL FEATURES:

RS232: Used for data transfer and remote control. BAUD rate 300 to 4,800. Software Handshaking.

Non Volatile Memory: The Model 908 will retain stored measurements for up to 2 months after the Model 908 is switched off.

External PSU Socket: The External PSU (not supplied) may be used to power the Model 908 when used in bench top applications.